

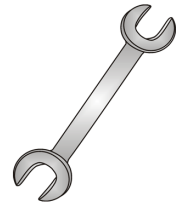

Tow-Trust Towbars

Important: Please read General Notes overleaf before fitting



Issue 4

TR858 RENAULT MEGANE SPORTS TOURER EST 2003 – 2009 RENAULT MEGANE II COUPE CABRIOLET 2003 – 2010 RENAULT MEGANE SPORTS SALOON 2003>

Item	Qty	Description	Item	Qty	Description
A	1	Crossmember	E	2	M16 x 50 Bolts, Nuts & S/P Washers
B	1	L/H Side Arm	F	2	M12 x 85 Grade 10.9 Bolts, Nyloc Nuts
C	1	R/H Side Arm	G	2	M12 x 35 Bolts, Nuts & S/P Washers
D	1	Extension Bar	H	2	M12 x 45 Bolts & S/P Washers
			J	2	M10 x 35 Bolts & S/P Washers
			K	6	12 x 25 Flat Washers
			L	2	12 x 40 Flat Washers
			M	2	10 x 40 Flat Washers

- Temporarily disconnect and remove the rear light clusters (three nuts and pull clusters rearward).
- Remove the rear bumper. **Saloon & Coupe Cabriolet** Six fixings along the underside, six fixings along the top edge and two fixings on the rear side of each wheel arch.
- Remove the rear bumper. **Tourer** Six fixings around each light cluster, Seven fixings along the underside, and three fixings on the rear side of each wheel arch (one of these are behind each mud flap), (Pull bumper outwards and upwards then rearward). NOTE: These are only a guide.
- Remove reinforcement beam (this is not refitted with the towbar).
- Coupe Cabriolet.** You may find it necessary to trim the brackets for counter balance weights on some models to allow for the arm assemblies.
- Remove the rubber chassis covers, left hand side bumper stiffener, spare wheel and jack assembly.
- Locate Item **B** into the left hand chassis and Item **C** into the right hand chassis and using Item **J** with Item **M** loosely bolt to the existing forward most holes in each chassis member. Note: existing holes in chassis are covered in tape.
- Using Item **H** with Item **L** (forward hole) and Item **G** with Item **K** (rear hole) loosely bolt Item **A** to Item **B** and Item **C**. Note: access for tightening Item **H** is on the left hand side, gained by lifting loading lip plastic trim inside the boot and removing the four fixings hidden under the plastic caps, move aside rear side panel and foam and remove blanking plug on the outer skin of the rear wing, or by temporarily removing the air vent on the side of the chassis panel.
- Fully tighten all nuts and bolts and ensure the towbar is rigid and secure.
- Note: it is recommended the open ends of the chassis are resealed to prevent water damage.
- Temporarily bend bumper tags down and replace the bumper. Note: **coupe cabriolet** will require a cut. SEE SKETCH.
- Refit all trim, accessories and light clusters.
- Using Item **F** with Item **K** bolt Item **D** to Item **A**.
- Using Item **E** bolt the ball bracket and wiring plate (not supplied in this kit) to the mounting plate.

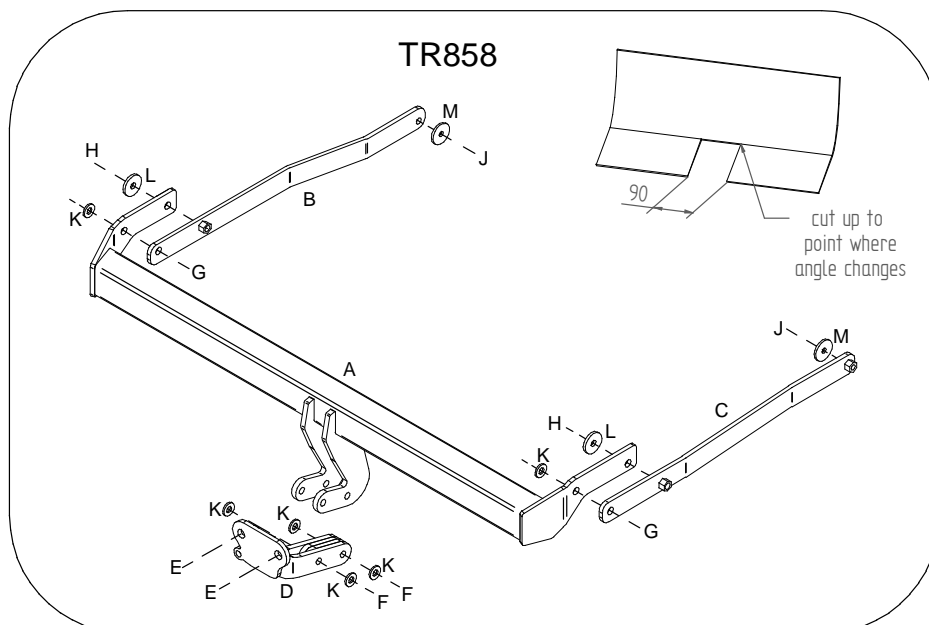

- Note:** 1. Recommended Torque Setting for M12 Grade 10.9 -139 Nm. (For other Torque Settings see notes overleaf.)
2. Nose load limits and vehicle manufacturers' trailer / caravan weight limits must be observed.