



Fitting Instructions

TOWBAR F125U
For Ford S-Max 2006-
Ford Galaxy 2006-

MATERIALS

A	1	Cross Bar
B	2	Bracket
D	2	Bolt Straps
E	2	Long Bolt Straps
F	2	M10 x 1.5 pitch Nuts, Lock Washers, Flat Washers (OD 30mm)
G	4	M10 x 1.5 pitch Nuts, Lock Washers, Flat Washers (OD 30mm)
H	6	M12 x 40 x 1.75 pitch Bolts, Nuts, Lock Washers
J	1	Foam Bumper Support Strip
K	1	Flip-Up Electrical Plate
M	1	Electrical Plate Bracket
ZQ	1	Tow Ball Neck ZF3022 or ZQ3022 or ZQF3022

FITTING

1. Remove bumper. (2 screws securing each wheel arch liner and 2 screws behind each liner, 6 screws along top edge, 2 plastic nuts on bottom edge).
2. Remove plastic bumper support tray and steel bumper beam.
3. Lower the rearmost exhaust silencer and remove the exhaust heat shield.
4. Insert Brackets (B) into chassis rails and loosely secure with Bolt Straps (D) and fasteners (G). **Note: Use holes shown for S-Max vehicles and holes (G1) for Galaxy vehicles.**
5. Assemble Long Bolt Straps (E) through Brackets (B) and secure using fasteners (F). **Note: Use holes shown for S-Max vehicles and holes (F1) for Galaxy vehicles.**
6. Assemble Crossbar (A) to Brackets (B) using fasteners (H).
7. Cut Foam Bumper Support Strip (J) into three equal lengths, peel off protective backing paper and stick to top of Crossbar (A) as shown.
8. Assemble the chosen Tow Ball Neck variant and Bracket (M) to Cross Bar (A) using separate fitting instructions
9. Assemble Flip-Up Electrical Plate (K) to Bracket (M) using separate instructions. Tighten as appropriate to allow rotation of the Electrical Plate Bracket up into the bumper when not towing.
10. **Fully Tighten all Fasteners**
11. Refit the exhaust heat shield and silencer.
12. Cut bumper as shown and refit to vehicle.

Note: This towbar must be used with either a Witter Towball (part number ZGF3022 or ZQ3022) or Class A50-1 or A50-X towball Dimensionally Conforming to A50-1 with a 'D' and 'S' value greater than or equal to that of the towbar.

Please refer to the vehicle specification for the trailer weight and nose limits, which **must be observed**.

Recommended torque settings: M8 - 27Nm, M10 - 53 Nm, M12 - 95 Nm, M14 - 150 Nm, M16 - 214 Nm

Grade 10.9: M12 - 139Nm, M10 - 78Nm



W0001F125U-FIT\$010803260000



Fitting Instructions

TOWBAR F125U
For Ford Mondeo Hatch/Saloon
July 2007-

MATERIALS

A	1	Cross Bar
B	2	Bracket
D	2	Bolt Straps
E	2	Long Bolt Straps
F	2	M10 x 1.5 pitch Nuts, Lock Washers, Flat Washers (OD 30mm)
G	4	M10 x 1.5 pitch Nuts, Lock Washers, Flat Washers (OD 30mm)
H	6	M12 x 40 x 1.75 pitch Bolts, Nuts, Lock Washers
J	1	Foam Bumper Support Strip
K	1	Flip-Up Electrical Plate
M	1	Electrical Plate Bracket
ZQ	1	Tow Ball Neck ZF3022 or ZQ3022 or ZQF3022

FITTING

1. Remove bumper. (3 screws in wheel arch, 2 screws on top edge, 2 plastic screws on bottom edge, pull tips away from body clips.).
2. Remove steel bumper beam to expose openings into chassis rails.
3. Lower the rearmost exhaust silencer and remove the exhaust heat shield.
4. Insert Brackets (B) into chassis rails and loosely secure with Bolt Straps (D) and fasteners (G) **Note: Use holes shown for Hatchback (5 door) vehicles and holes (G1) for Saloon (4 door) vehicles.**
5. Assemble Long Bolt Straps (E) through Brackets (B) and secure using fasteners (F). **Note: Use holes shown for Hatchback (5 door) vehicles and holes (F1) for Saloon (4 door) vehicles.**
6. Assemble Crossbar (A) to Brackets (B) using fasteners (H).
7. Assemble the chosen Tow Ball Neck variant and Bracket (M) to Cross Bar (A) using separate fitting instructions.
8. Assemble Flip-Up Electrical Plate (K) to Bracket (M) using separate instructions. Tighten as appropriate to allow rotation of the Electrical Plate Bracket up into the bumper when not towing.
9. **Fully Tighten all Fasteners**
10. Refit the exhaust heat shield and silencer.

Note: Item (J) is not required for Hatch and Saloon vehicles.

Note: This towbar must be used with either a Witter Towball (part number ZF3022 or ZQF3022 or ZQ3022) or Class A50-1 or A50-X towball Dimensionally Conforming to A50-1 with a 'D' and 'S' value greater than or equal to that of the towbar.

Please refer to the vehicle specification for the trailer weight and nose limits, which **must be observed**.

Recommended torque settings: M8 - 27Nm, M10 - 53 Nm, M12 - 95 Nm, M14 - 150 Nm, M16 - 214 Nm

Grade 10.9: M12 - 139Nm, M10 - 78Nm



W0001F125U-FIT\$010803260000

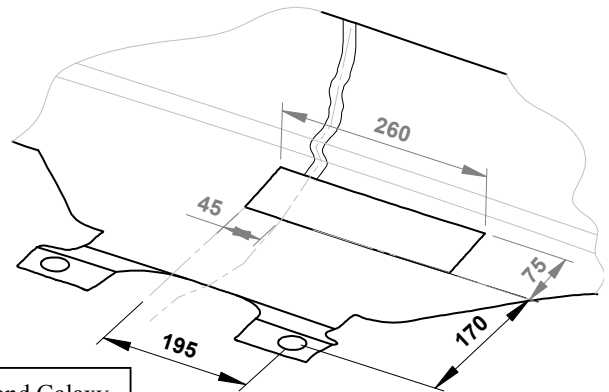
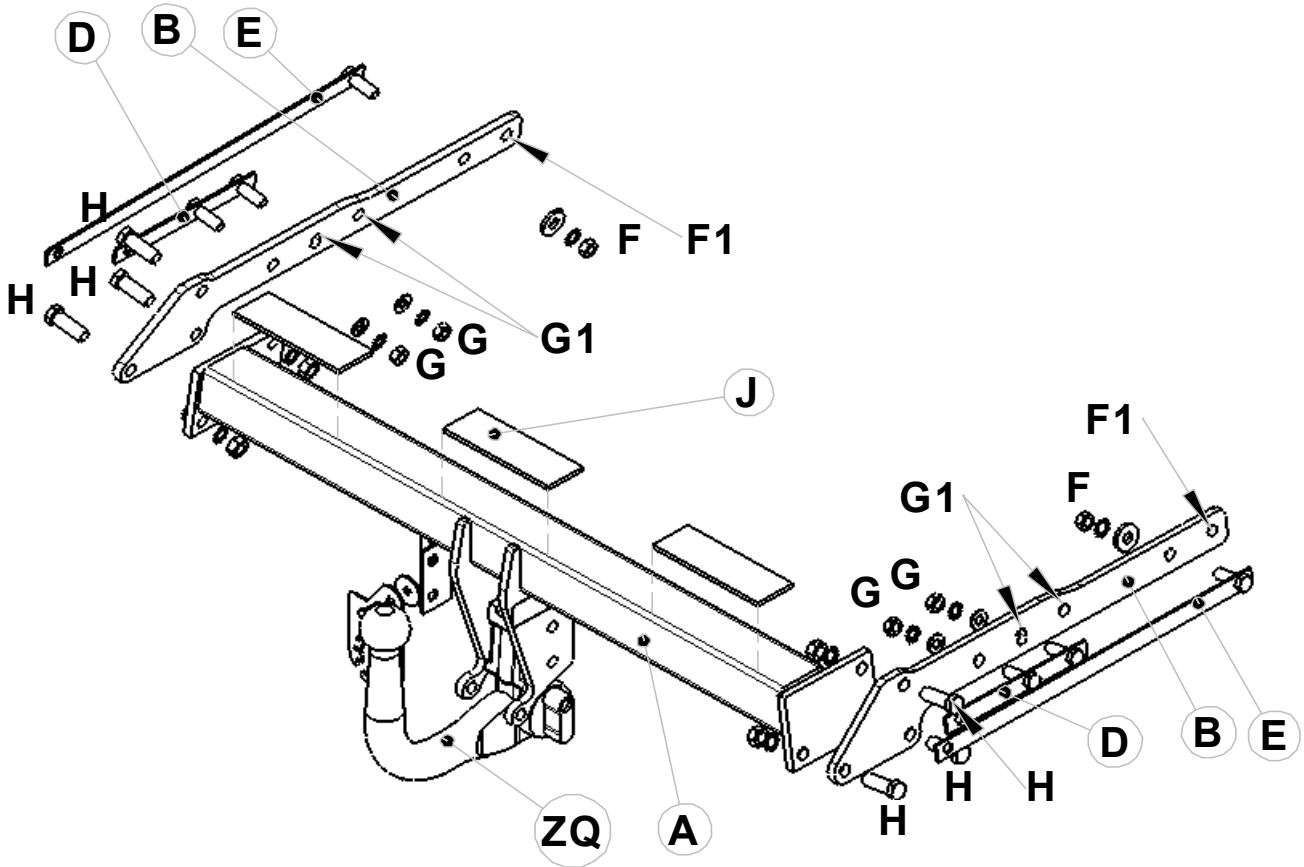
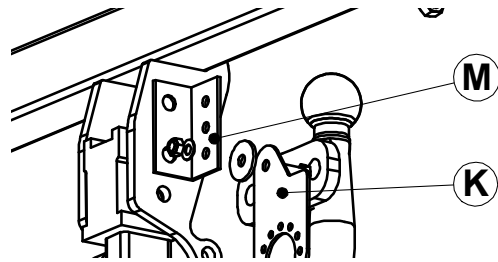

S-Max and Galaxy
Bumper Cut



W0001F125U-FIT\$010803260000