

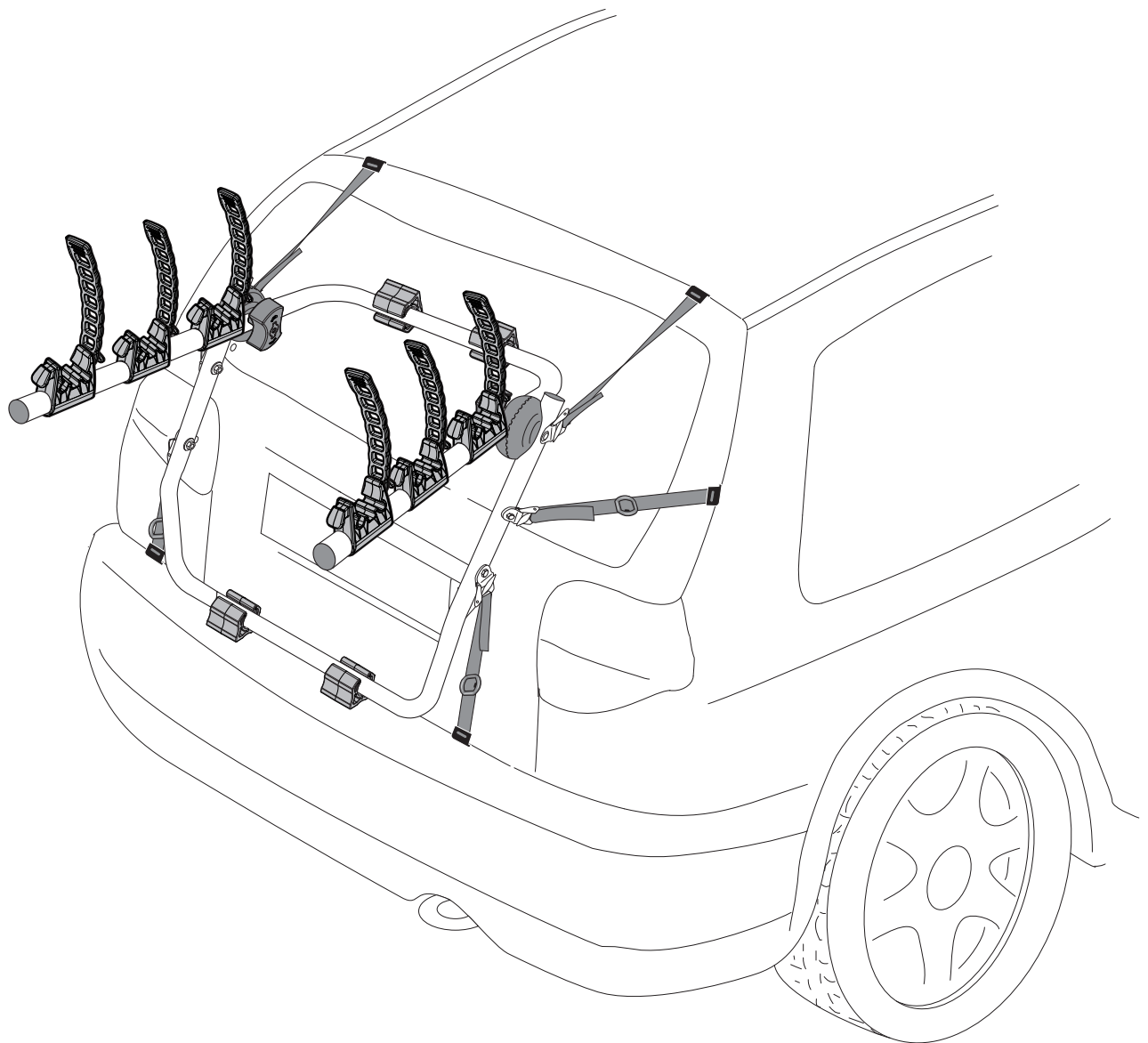

## CYCLE CARRIER



# Fitting & Usage Instructions

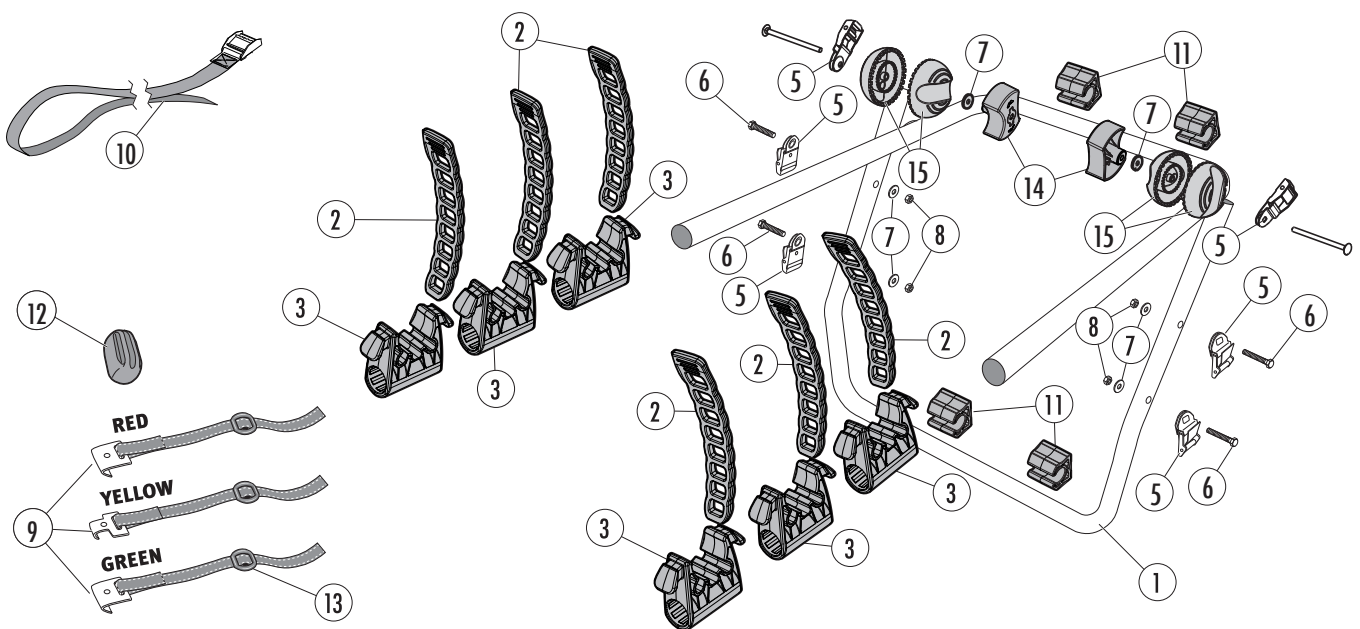
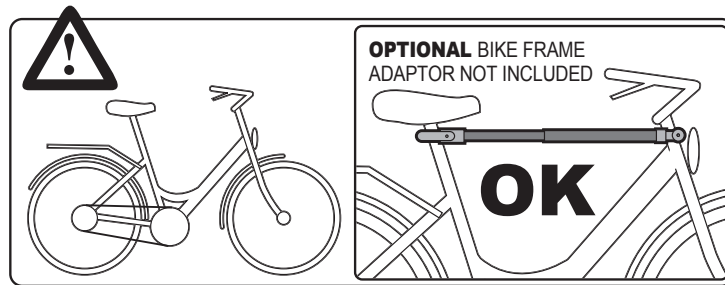

N.	Components (Included)	Q.
1		1
2		6
3		6
5		4
6		4
7		4
8		4

9		<b>RED</b> 	2
		<b>YELLOW</b> 	2
		<b>GREEN</b> 	2
10		<b>~2,5MT</b>	1
11			4
12			4
13			4

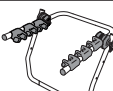

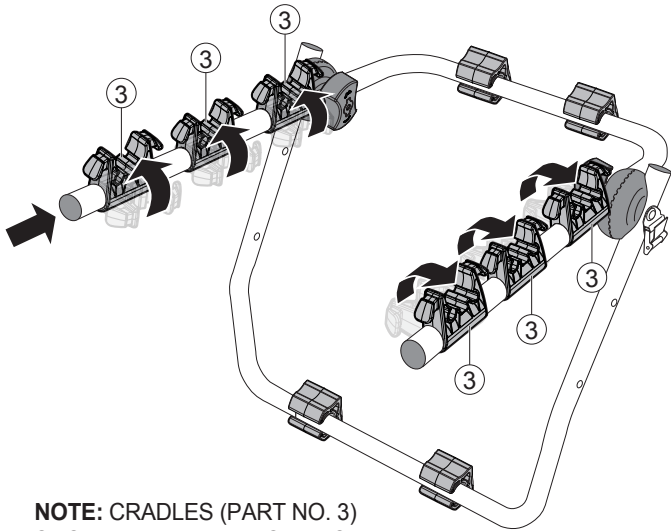

N.		Q.
1		1
11		4



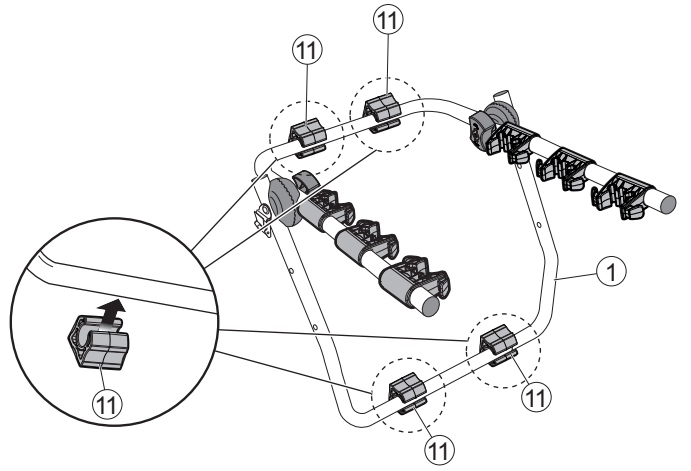

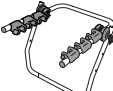
**NOTE:** CRADLES (PART NO. 3) SHOULD BE FITTED AS INDICATED

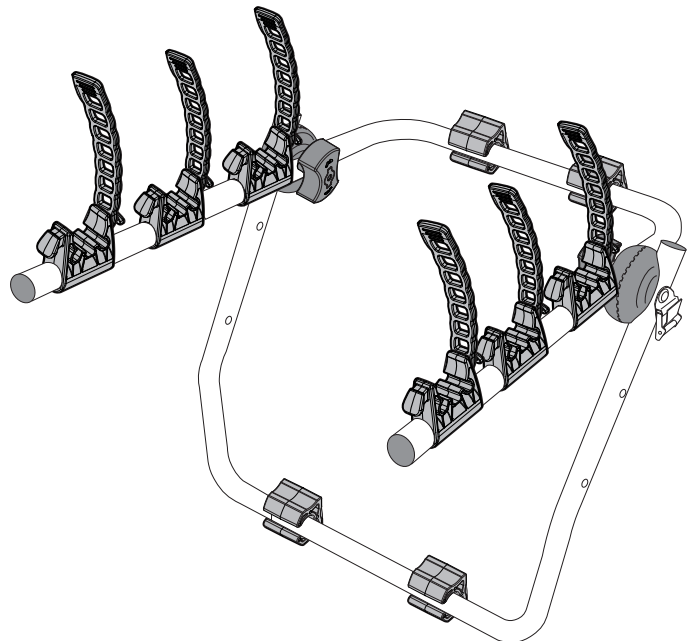
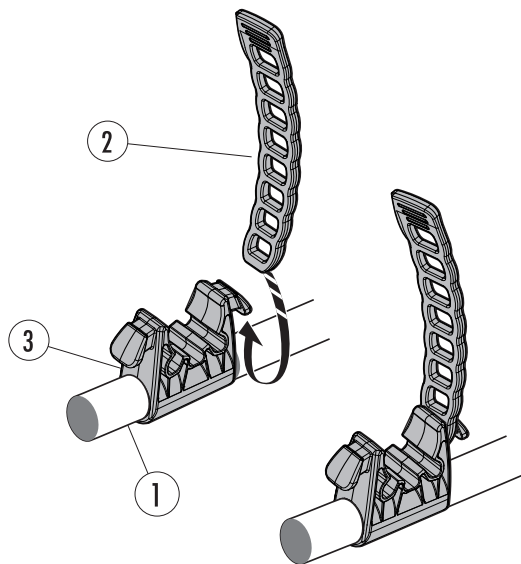
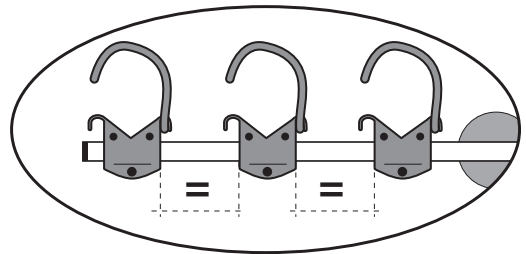

N.		Q.
1		1
2		6

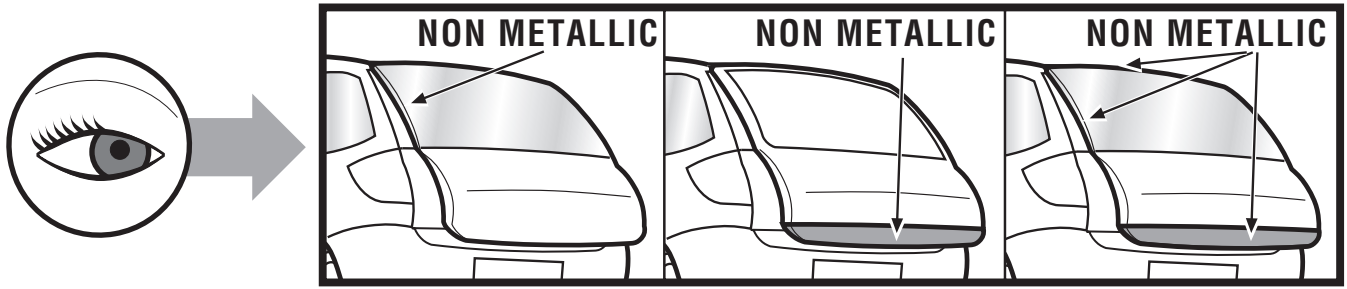







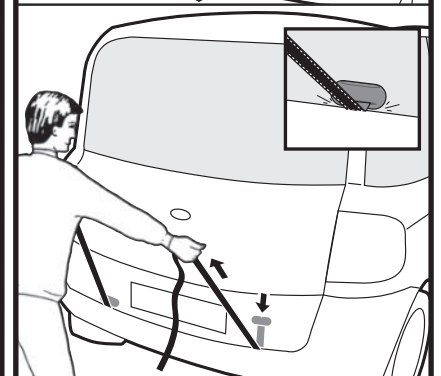
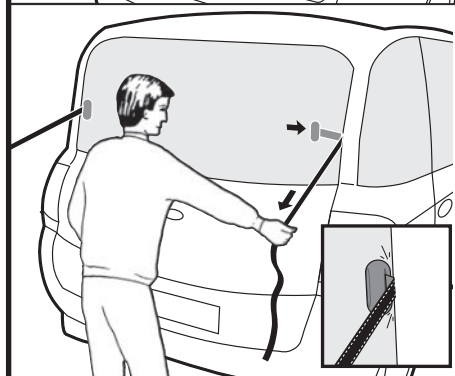
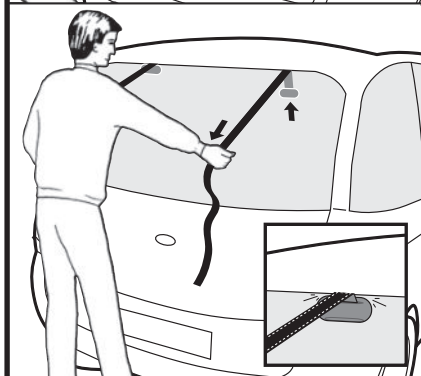
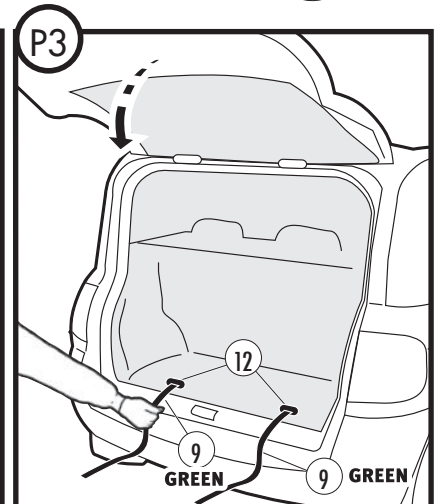
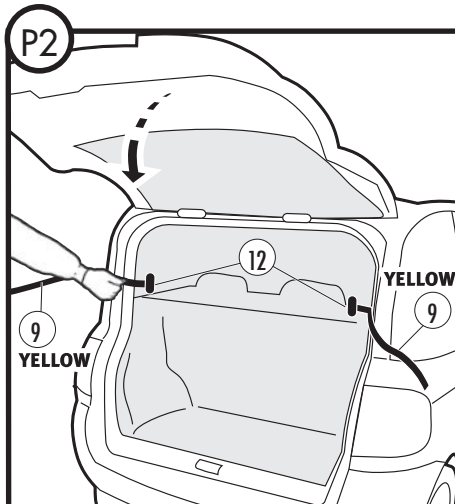
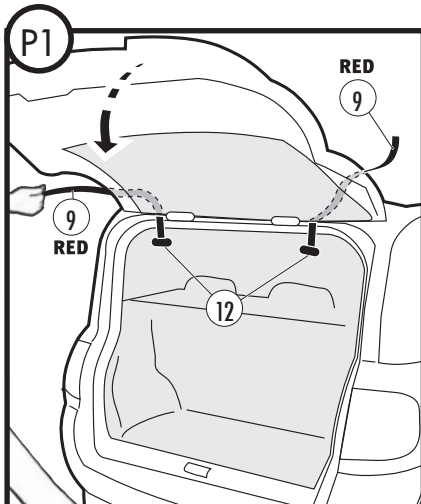
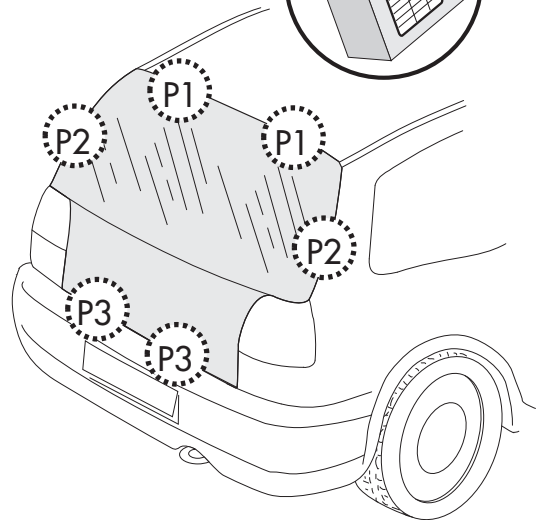
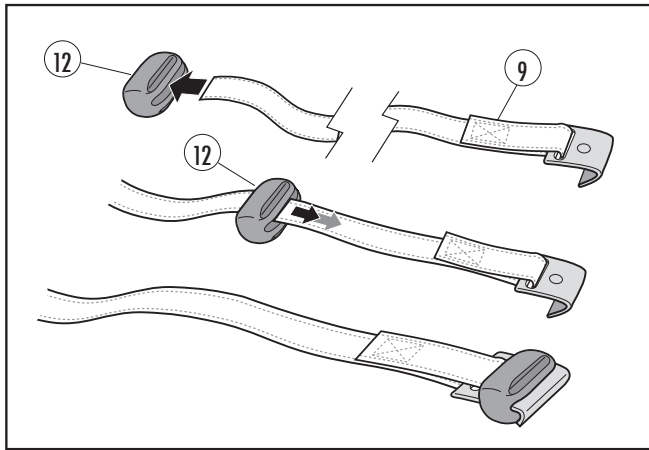
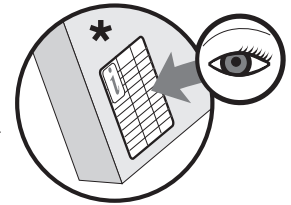

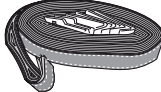

N.		Q.
12	 *	2/4

IF NECESSARY CONSULT  
VEHICLE MANUFACTURING  
HANDBOOK



N.		Q.	
8		4	
6		4	
5		4	
7		4	
9		<b>RED</b> 	2
		<b>YELLOW</b> 	2
		<b>GREEN</b> 	2
13		4	

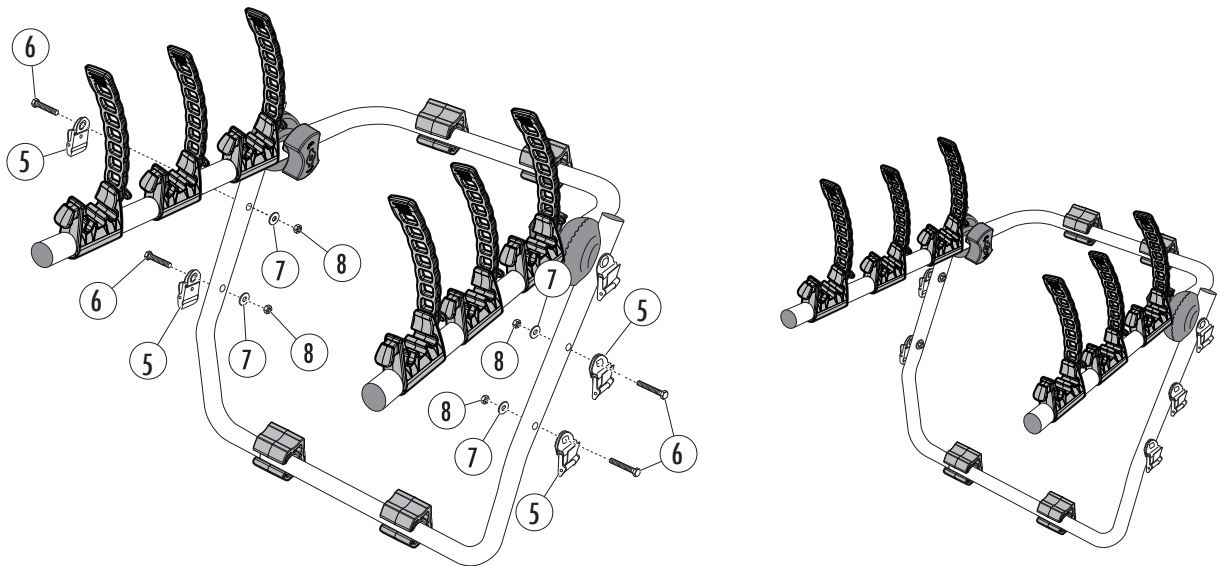

**NOTE:** FULLY TIGHTEN ALL FIXINGS AT THIS POINT. DO NOT OVER-TIGHTEN.

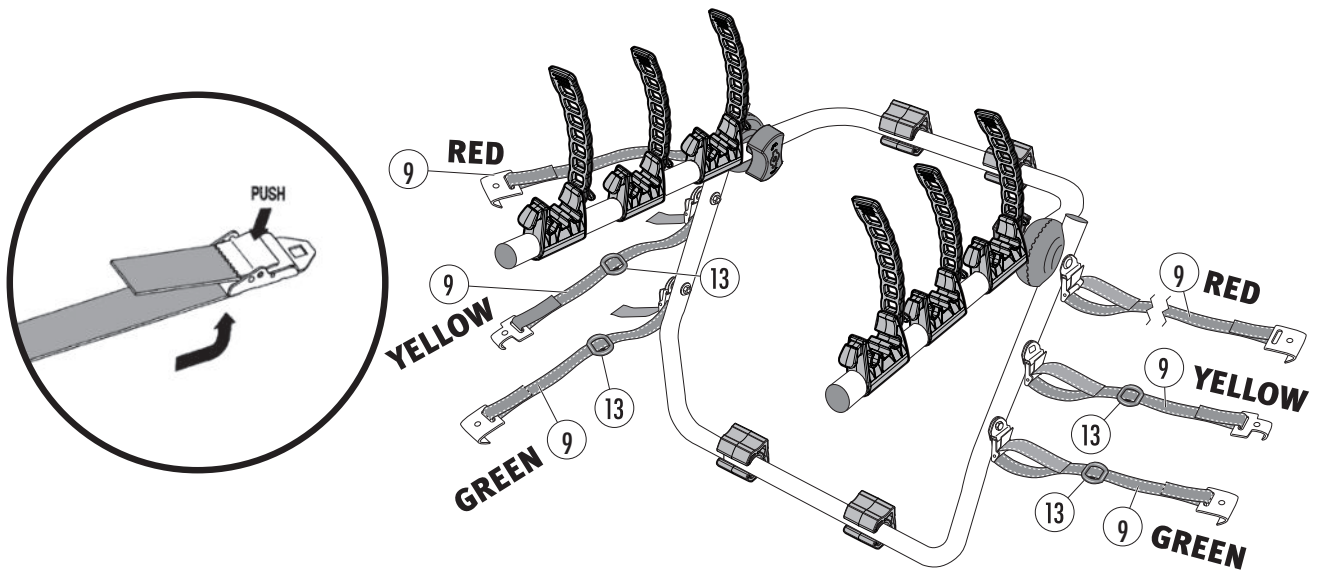

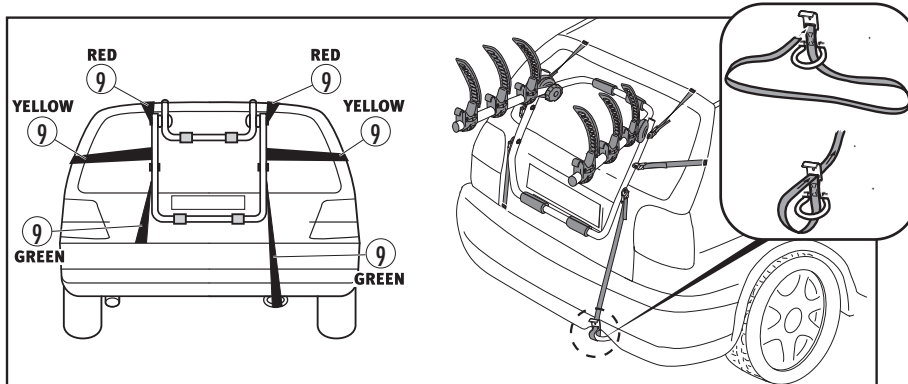
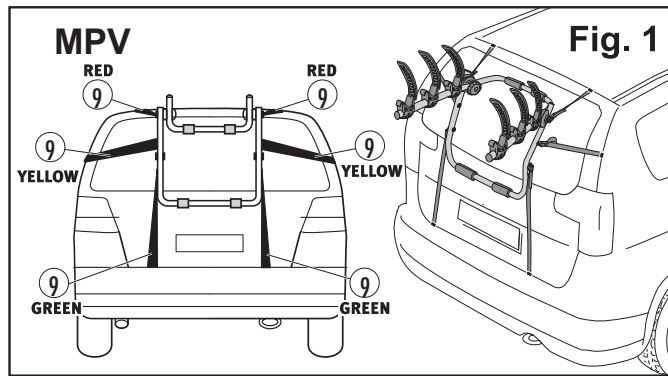
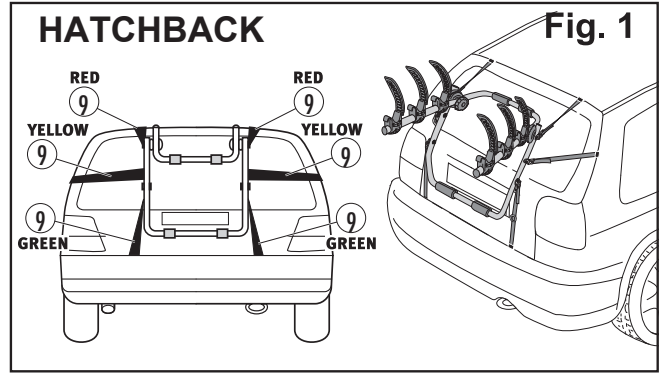
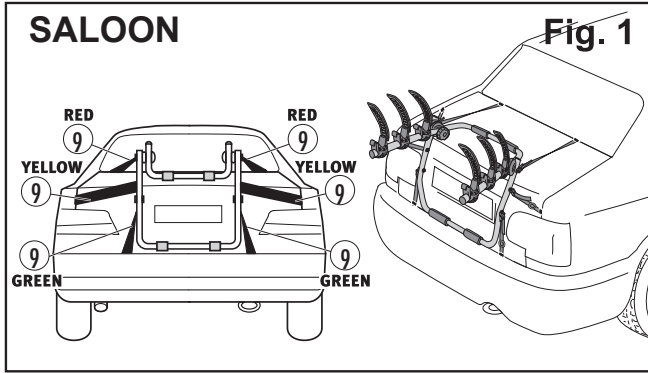

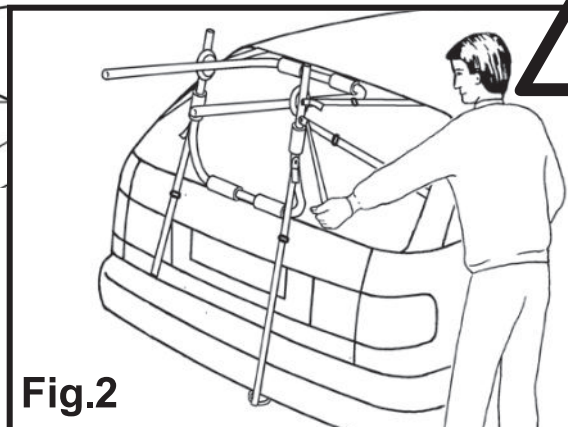

WHEN FITTING THE CARRIER TO THE VEHICLE THE ENDS OF THE CYCLE SUPPORT ARMS MUST BE POSITIONED UPWARDS.

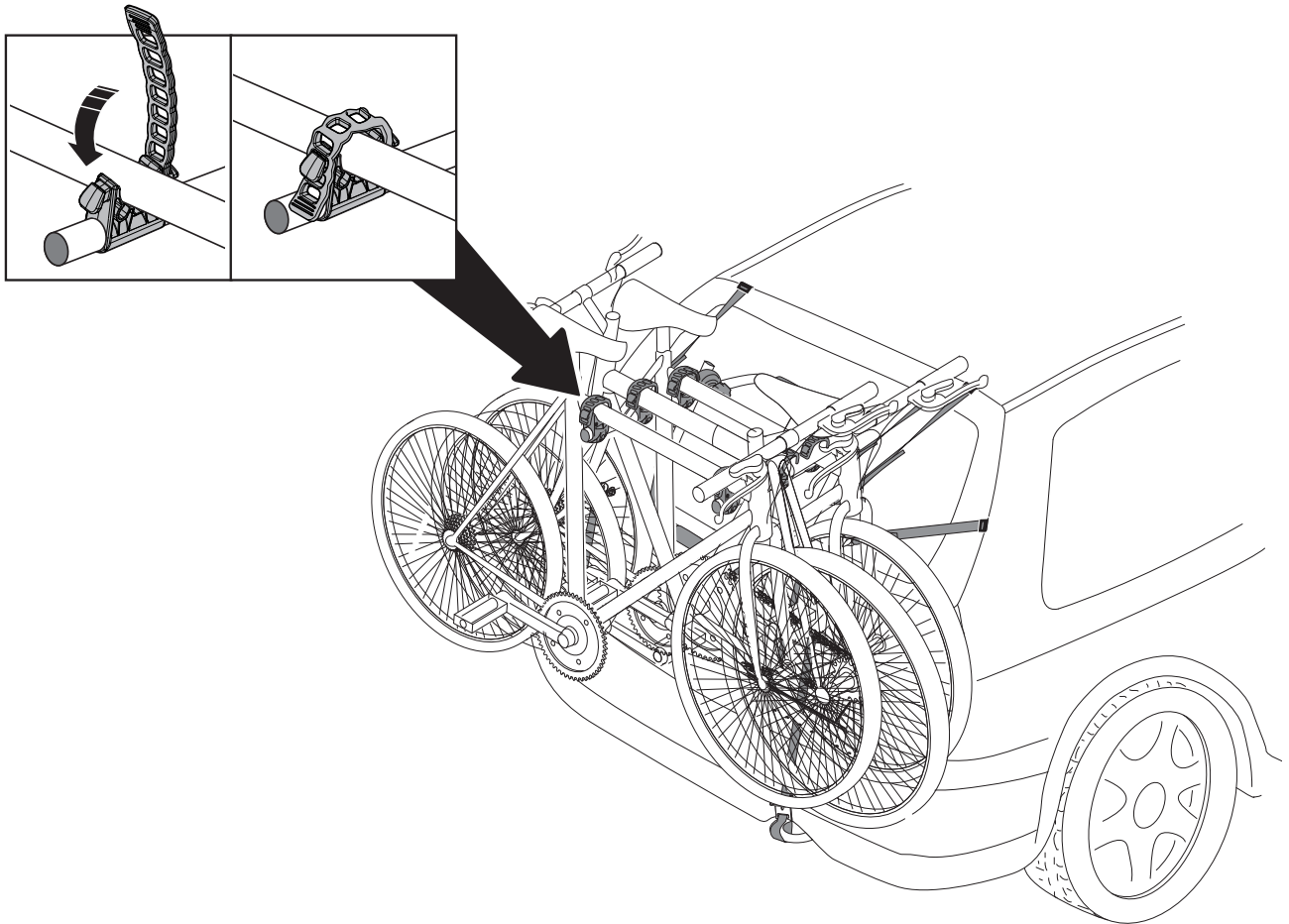

**Fig.2**

ENSURE THE CARRIER IS SECURELY ATTACHED TO THE VEHICLE



N.		Q.
10	 ~2,5MT	1



All cycles **MUST** be secured to the cycle carrier by using the strap provided (item 10). Ensure the strap is passed round the cycle carrier frame but not round the cycle support arms.

Ensure all 3 sets of fixing straps have been correctly attached to the carrier and fitted to the vehicle in the correct positions. Ensure that bicycles do not come into contact with the vehicle bodywork and provide protection as required. Cycles should be positioned clear of the vehicle's exhaust. During your journey, frequently check the tension of carrier fixing straps and the security of the cycles carried.

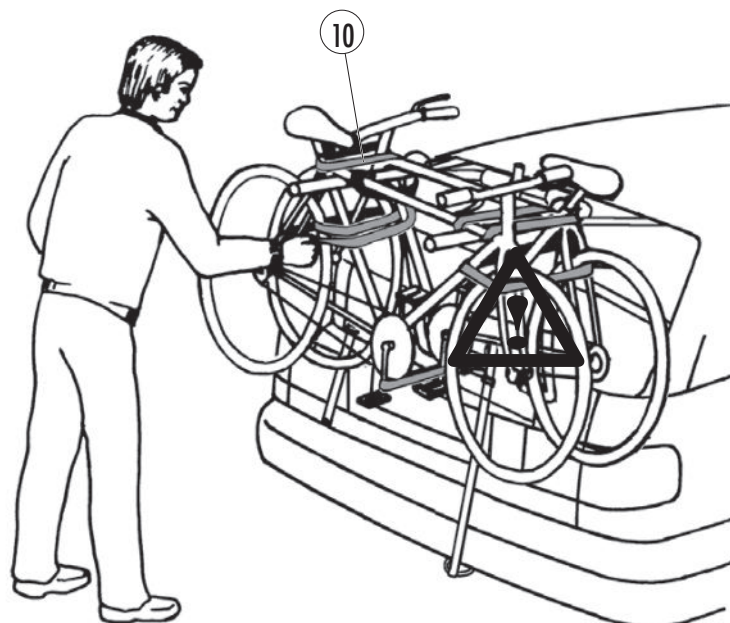

This carrier has been designed, manufactured and tested carefully, in compliance with all product standards in force. For your safety and that of all travellers, please read the following information carefully before assembling, fitting or loading the carrier. Retain this booklet for future use.

1. The attachment of this carrier to a vehicle is safety critical and beyond the control of the manufacturer. The user must therefore ensure that the cycle carrier is suitable for use with their particular vehicle and that both carrier and cycles are securely and safely attached to the vehicle. You are entirely responsible for your safety and that of others whilst your vehicle is being used.
2. Assemble and install the carrier as shown in this instruction booklet. Do not fit or use the product if you are in doubt regarding the assembly. Do not install or use the product if any parts are missing. The manufacturer does not assume any responsibility for damage caused due to incorrect assembly of the carrier. Do not modify or tamper with the carrier under any circumstances.
3. Clean the vehicle surface in the location that the carrier will be mounted, to avoid damage to paintwork. After mounting the carrier on the vehicle, check that all straps and fixings are fully tightened. Forcibly check that the carrier is secured properly onto the vehicle, repeat this after positioning the cycles on the carrier.
4. Roof or boot spoilers and plastic trims may prevent the correct fitting of the cycle carrier as straps and carrier framework should not be in contact with them when fitted. The rear windscreen wiper (if fitted) may be obstructed by the cycle carrier, do not use.
5. Do not attach the hooks to glass or plastic panels. For vehicles with glass to the top of the hatch or plastic panels, the adaptor blocks (item 12) bars must be used. These blocks may also be used where there is limited space to insert the hooks between panels.
6. The maximum carrying capacity of this product is 3 cycles not exceeding a total of 45Kg. Check the weight of your cycles, a typical mountain bike may weigh 16Kg. Check the vehicle manufacturer's specification to ensure that you do not overload the rear hatch or door.
7. Ensure all 3 sets of fixing straps have been correctly attached to the carrier and fitted to the vehicle in the correct positions.  
Secure all cycles to the carrier using the strap (Item 10) provided. Ensure that bicycles do not come into contact with the vehicle bodywork and provide protection as required. Cycles should be positioned clear of the vehicle's exhaust. During your journey, frequently check the tension of carrier fixing straps and the security of the cycles carried.
8. Remove any loose objects from the cycles carried i.e. pumps, bottles, baby seats etc. Do not use cycle covers when travelling.
9. If possible avoid any protrusions beyond the side of the car as these may present a risk of injury to passers - by. The load should never protrude more than 40cm to the side of the rear lights. Should your rear lights or number plate be obscured when carrying cycles, an auxiliary lighting board and number plate must be used. Lighting boards and wiring systems are specifically designed for this purpose.
10. Installation of cycle carriers on the rear of the vehicle will increase the vehicle dimensions; take great care while crossing speed bumps or ramps. With a loaded cycle carrier fitted, the vehicle must be driven with care, be aware of cross winds, avoid sudden braking or hard cornering, reduce speed accordingly when using the carrier. Anyone else using your car with this accessory installed on it must be informed of these instructions.
11. If towing a trailer with the carrier fitted, ensure that sufficient clearance exists between the draw bar and cycles to allow for manoeuvring.
12. This carrier is designed for temporary use only; remove when not in use or before going through a car wash. In order to reduce fuel consumption, remove the product from the car when it is not being used.
13. Do NOT use this product if any part is worn or damaged. If in any doubt about the safe installation and use of this product please contact Maypole Ltd 0121 270 4301