

FITTING INSTRUCTIONS

Fiat Scudo / Citroen Despatch /
Peugeot Expert

2007-

TFT081 101132

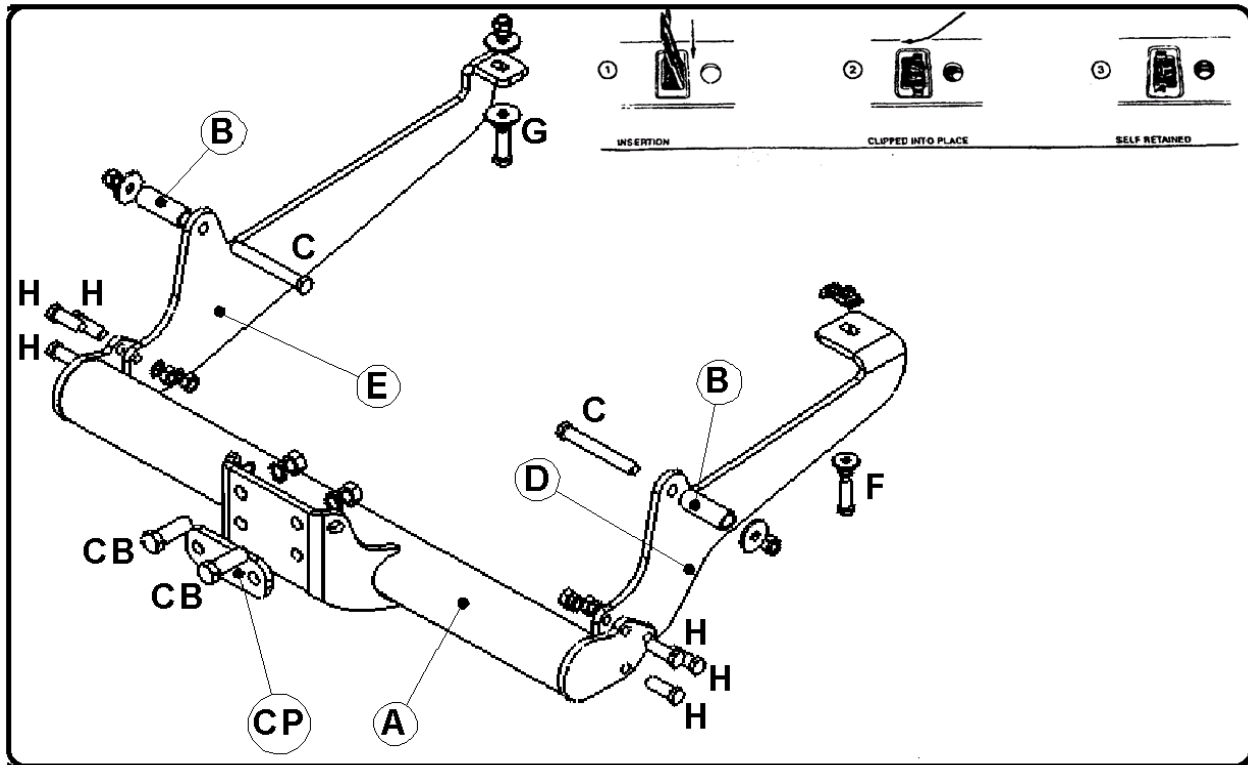

MATERIALS

A	1	Cross Bar with European facing to 94/20/EC A50-1
B	2	Bush Tube (22mm O.D x 67 long)
C	2	M12 x 110 x 1.75 pitch Bolts, Nyloc Nut and Flat Washer (O.D. 40mm)
D	1	Side Bracket
E	1	Side Bracket
F	1	M10 x 40 x 1.5 pitch Bolt, Lock Washer, Flat Washer (O.D. 30mm) and Captive Nut (M10 Large Frame)
G	1	M12 x 40 x 1.75 pitch Bolt, Nut, Lock Washer, and 2 Flat Washers (O.D. 40mm)
H	6	M12 x 40 x 1.75 pitch Bolts, Nuts, and Lock Washers
I	1	ZEP35 Electrical plate (not shown)
CP	1	Spacer
CB	2	M16 x 60mm Coupling Bolts, Nuts, Lock Washers

FITTING

1. Lower spare wheel to ease assembly of Side Brackets.
2. Assemble Side Brackets (D) and (E) to inner face of Chassis rails using fasteners (C), inserting Bushes (B) into the chassis from the opposite side.
3. Secure the Side Brackets (D) and (E) to forward most mountings using fasteners (F) and (G). Note: The Captive Nut (F) may need its frame compressing very slightly or the rectangular hole that it is fed through may need very slight enlargement to ease fitment.
4. Assemble Cross Bar (A) to Side Brackets using fasteners (H)
5. Fully tighten all fasteners.
6. Raise spare wheel back into position.

Note: This towbar must be used with a Class A50-1 or A50-X towball, which dimensionally conforms to A50-1 with a 'D' and 'S' value greater than or equal to that of the towbar.

Recommended torque settings: Grade 8.8 bolts: M8 - 24Nm, M10 - 52 Nm, M12 - 80 Nm, M14 - 130 Nm, M16 - 200 Nm
Grade 10.9: M12 - 120Nm, M10 - 70Nm M8- 35Nm