

FITTING INSTRUCTIONS

FORD FIESTA

2002 –

TFO040 101054

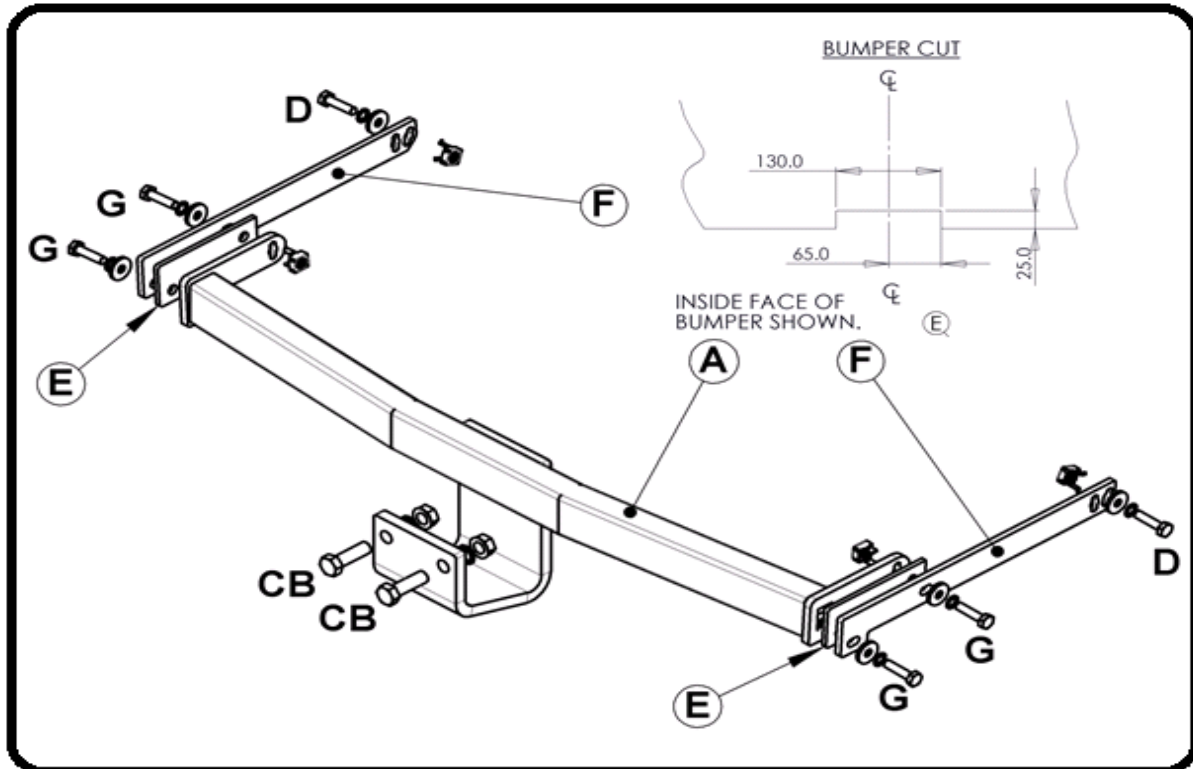

MATERIALS

A	1	Cross Bar with European facing to 94/20/EC A50-1
D	2	M10 x 40 x 1.5mm Set Screws, Lock Washers, Flat Washers (30mm O.D.), Cage Nut & Retainers
E	2	Spacer
F	2	Side Arm
G	4	M10 x 45 x 1.5mm Bolts, Lock Washers, Flat Washers (30mm O.D.), 2 - Cage But & Retainers
P	2	Pop Rivets
CB	2	M16 x 50mm Coupling Bolts, Nuts, Lock Washers & 1 Safety Chain Plate (SCP4)

FITTING

1. Remove bumper. Drill out 2 pop rivets on top edge of bumper (Pre 2008 vehicles only). Remove inner bumper beam. Assemble Cage Nut to forward most mounting on Side Arms (F). Insert Side Arms (F) into chassis rails and secure using fasteners (D)
2. Pre September 2008 Vehicles:
 - a. Assemble Cage Nuts (G) to Cross Bar (A).
 - b. Slide Cross Bar (A) into chassis rails and push up against lower plastic bumper bracket, mark either side of drop plate, remove Cross Bar and cut out plastic section. Re-mount Cross Bar (A) and attach using remaining fasteners (G). Ensure face plate is vertical and tighten all bolts.
3. Post September 2008 Vehicles:
 - a. Assemble Cage Nuts (G) to Cross Bar (A).
 - b. Slide Cross Bar (A) into chassis rails, align with rearmost vehicle mounting point, insert spacers (E), and loosely secure using remaining fasteners (G) and fasteners (D).
4. Fit the Safety Chain Plate.
5. Fully tighten all fasteners.
6. Cut bumper as shown and re-fit to vehicle.

Note: This towbar must be used with either a Class A50-1 or A50-X towball dimensionally Conforming to A50-1 with a 'D' and 'S' value greater than or equal to that of the towbar. Please refer to the vehicle specification for the trailer weight and nose limits, which must be observed.

Recommended torque settings: M8 - 27Nm, M10 - 53 Nm, M12 - 95 Nm, M14 - 150 Nm, M16 - 214 Nm